



WINDSOR
WINDOWS & DOORS
A Woodgrain Millwork Company

Installation Guidelines and Homeowner Warranty

(Waiver Opt-Out Information Enclosed)

FOR NEXT DIMENSION PRODUCTS

Single Hung / Double Hung

Sliding Window / Fixed Window / Casement

Provide to Homeowner

900 South 19th Street • West Des Moines, IA 50265 • 515.223.6660 • 800.218.6186
2210 Stafford Street Extension • Monroe, NC 28110 • 704.283.7459 • 800.205.5665

www.windsorwindows.com

#661522_010117_P1

Installation Guidelines

FOR NEXT DIMENSION WINDOWS

Installer

- Read instructions completely before attempting installation. Failure to follow these guidelines will void the Windsor warranty coverage, written or implied.
- Always provide a copy of these instructions to the homeowner.
- These instructions are consistent with ASTM 2112 “Standard Practice for Installation of Exterior Windows, Doors and Skylights” into common wall constructions. Contact your architect or construction professional for installation into other building designs or construction methods.
- Regional codes and environmental conditions may require installation that is different from these guidelines. It is your responsibility to ensure that local codes and ordinances are followed.

Warning!

- ⚠ **Work Safe!** Always wear proper eye and hearing protection when installing or adjusting Windsor products.
- ⚠ **Use Power Tools Properly!** To avoid personal injury, always follow manufacturers’ instructions for safe operation of power tools.
- ⚠ **Ladder Safety!** Working at elevated levels can be hazardous. Always use ladders and scaffolding properly. Consult manufacturers’ guidelines for safe use of these types of equipment.
- ⚠ **Safety Glazing!** Windsor products do not contain safety glazing unless specifically ordered that way. Use caution – injury could result if glass is broken and fragmented. Building codes require safety glazing for windows installed in certain areas. Consult your local building code official for guidelines.

Important

- Windsor reserves the right to change the information contained in these guidelines without notice.
- Maintain a minimum of 1/4" between the window frame and any trim, siding or masonry.
- Use of Windsor products in barrier EIFS systems (synthetic stucco) is not recommended. To do so will void all warranties (written or implied) and Windsor Windows & Doors will not be held responsible for any claims or damages resulting from water infiltration.
- Steel fasteners will corrode when used with ACQ pressure treated lumber. Use corrosion-resistant fasteners (such as stainless steel) when installing windows in or around these types of materials.
- Window nailing flanges and drip caps (integral or applied) do not take the place of window flashing. All windows and doors must be properly flashed and sealed around the perimeter.
- Certain Windsor double hung products are furnished with jamb jacks. Jamb jacks are not required for installation, but rather future adjustment to the frame width at the middle of the unit. Jamb jacks should not be used in place of shims. Refer to Step 4 for shimming guidelines.

Handling and Storage

- Always carry door units upright. Do not carry flat! Doing so could result in damage to the unit.
- Do not store units outside.

IMPORTANT! IF VINYL WINDOWS AND DOORS ARE NOT INSTALLED IMMEDIATELY UPON DELIVERY, THEY MUST BE PROPERLY STORED AND PROTECTED UNTIL INSTALLED.









If the vinyl product is not stored properly, distortion of the frames can occur affecting operation and performance. Vinyl windows and doors should be installed within 30-60 days of receiving.

Follow these procedures for proper storage of vinyl windows and doors:

- Remove stretch wrap immediately so the individual units can be exposed to circulated air.
- Do not store units outside or in direct sunlight. Allow sufficient spacing between products for ventilation.
- Never store vinyl units in a closed truck or other enclosure.
- Never stack or lean vinyl units against each other in the sun.
- Always carry vinyl units upright. Do not carry flat! Doing so can result in damage to the unit.
- Always store vinyl units vertically. Do not store windows flat or stack horizontally.
- Vinyl units must be stored in a clean, dry, well-ventilated and enclosed area.
- Vinyl windows with unsupported nailing fins should have their corners blocked and protected to prevent damage to the nailing fin.

Failure to follow these procedures will void our product warranty.

Tools Needed

- | | | | |
|------------------|---|------------------------|---|
| • Safety Glasses |  | • Ladder / Scaffolding |  |
| • Utility Knife |  | • Square |  |
| • Hammer |  | • Tape Measure |  |
| • Caulk Gun |  | • Stapler |  |
| • Level |  | | |

Materials Needed

- Backer Rod
 - 1/4"-1/2" diameter closed cell foam
- Insulation
 - Minimally expanding low pressure polyurethane window and door foam
- Shims
 - Made of cedar or synthetic material
- Roofing Nails
 - 2" galvanized (16D)
- Silicone Sealant
 - 100% Silicone
 - Neutral cure (modified oxime) only
- Flashing
 - Self-adhesive flexible flashing that complies with ASTM-D779

LEAD PAINT AND EXISTING WINDOW DISPOSAL:

- A) Before any remodel or renovation, make sure to identify any potential lead paint issues and take necessary steps to reduce the risk of lead contamination.
- B) The U.S. Environmental Protection Agency (EPA) has issued a “Lead Renovation, Repair and Painting Rule (RRP)” for remodelers of older homes and buildings. This rule requires training and certification in lead-safe work practices for firms performing renovation, repair or painting on homes and child-occupied facilities built prior to 1978.
- C) For more information regarding procedures for dealing with lead paint, please visit EPA’s website at **www.epa.gov/lead**.
- D) When removing existing windows, make sure to wear appropriate personal protective equipment. Extra precautions should be taken to protect others and property within the vicinity and below the removal window and surrounding components.
- E) Consult with local waste authorities on the proper recycling or disposal of old window components.

ATTENTION! THIS DOCUMENT CONTAINS WAIVERS THAT AFFECT YOUR LEGAL RIGHTS.

Please read the entire document carefully, especially the section entitled, “Dispute Resolution Process,” because that section contains statements reflecting your agreement to waive your rights to a jury trial and to participate in a class action case related to a dispute you have with Windsor arising out of the Windsor products covered by this warranty. **YOU CAN OPT OUT OF THESE WAIVERS. To do so, please go to www.windsorwindows.com/support and locate the Waiver Opt-Out Form. In order to opt out of these provisions, you must fill out the Waiver Opt-Out Form within one year of the date your Windsor products were manufactured, as indicated by the glass code on the product.**

Step 1: Inspect Unit

Before Installation:

- A) Remove all shipping packaging material (blocks, pads, protectors, stretch wrap).
- B) Do not remove red double hung sash retainer clips (Next Dimension Signature product only) until after installation.
- C) Inspect unit for any damage or defects.
- D) Verify that the window unit is the correct size and configuration.
- E) Make sure the unit operates properly.
- F) Contact the nearest Windsor distributor if there is a problem.

Step 2: Apply Jamb Extension Clips or Drywall Return

- A) Place a 1/8" diameter bead of 100% neutral cure sealant around the interior perimeter of the frame in the recess shown. (Fig. 1)
- B) Install the 3" jamb extension clips around the perimeter of the frame, two on each corner, and then spaced on approximately 18" intervals along the frame. (Fig. 2) **Note: For drywall return, install lineal pieces.**
- C) Position the jamb extension as shown against the clips and staple or screw through the clip into the backside of the jamb extension. (Fig. 2)
- D) Wrap jamb extension around the window as shown. (Fig 3)

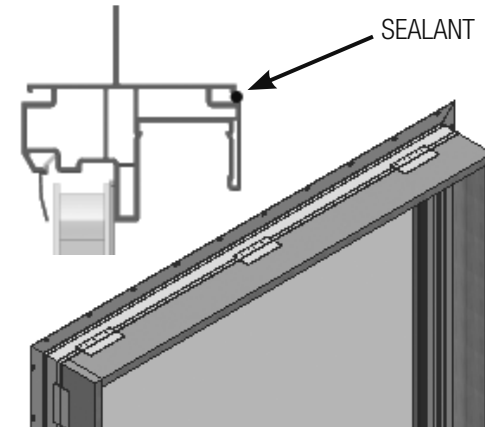

FIG. 1

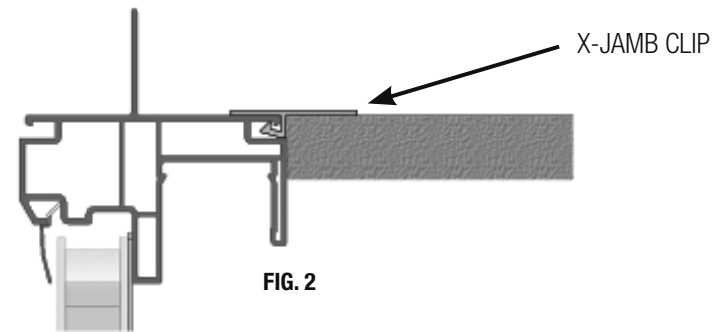

FIG. 2

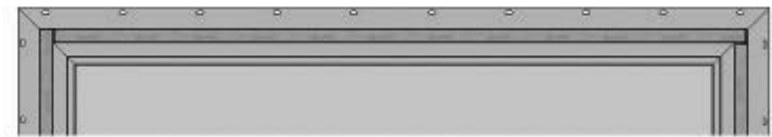

FIG. 3

Step 3: Prepare Rough Opening

- A) Measure and verify the size of the rough opening. The rough opening should be 1/2" larger than the frame in both width and height.
- B) Verify the rough opening is flat, plumb, level and square. (Fig. 4)
- C) Take diagonal measurements to check for square. (Fig. 4)
- D) Make sure the bottom sill area of the opening does not slope toward the interior.
- E) Cut the weather-resistant barrier (WRB) in a "Modified I" pattern shown below. (Fig. 5)
- F) Fold back the WRB on the sides and sill toward the interior and staple into place. (Fig. 6)
- G) From the exterior, cut the top of the WRB as shown to form a flap. (Fig. 7)
- H) Temporarily tape this top flap up. (Fig. 7)

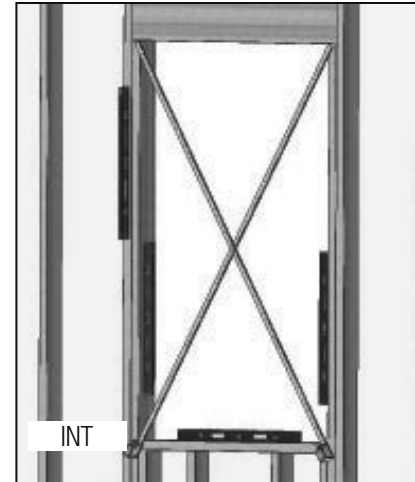

FIG. 4

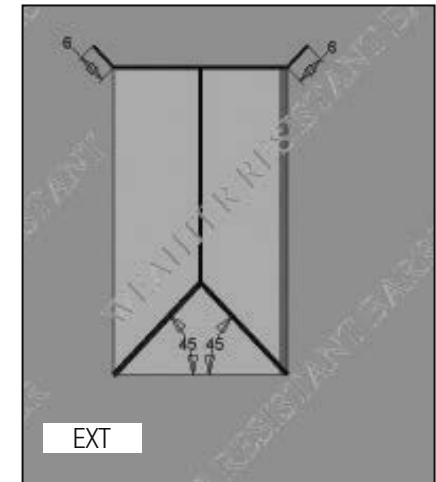

FIG. 5

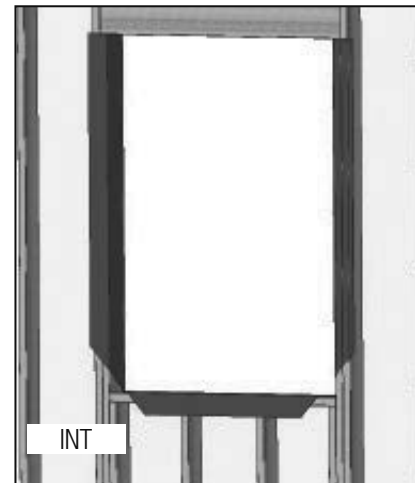

FIG. 6

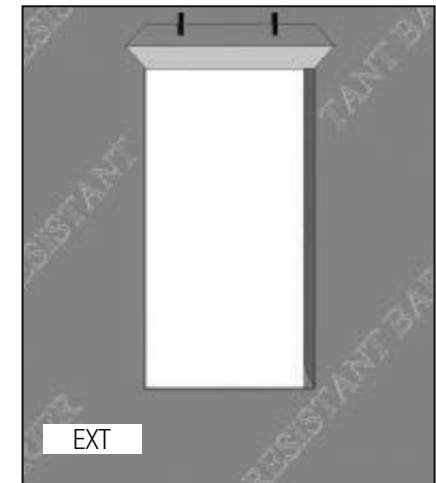
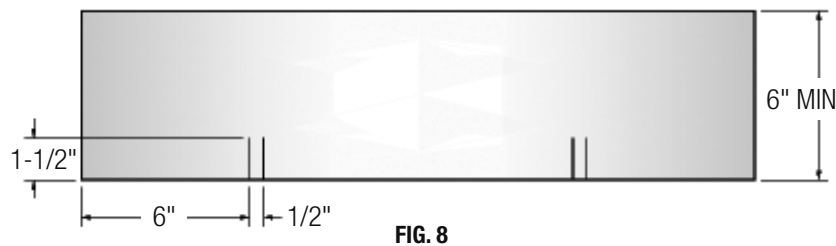

FIG. 7

Step 4: Flashing the Sill

- A) **IMPORTANT!**
- Use flashing that is 6" minimum in width.
 - Flashing must meet ASTM-D779 performance requirements.
 - Adhesive or mechanically-fastened flashing may be used.
- B) Measure the width of the rough opening. Cut a length of flashing that is 12" wider than the rough opening. This will allow you to run the flashing 6" up each side. (Fig. 8)
- C) Cut 1-1/2" slits at each end of the flashing as shown below. (Fig. 8)



- D) Apply sill flashing to the rough opening as shown below. (Fig. 9)
- E) If you are using non-adhesive flashing:
- Staple flashing into place.
 - Seal corner notches using 100% neutral cure silicone sealant.

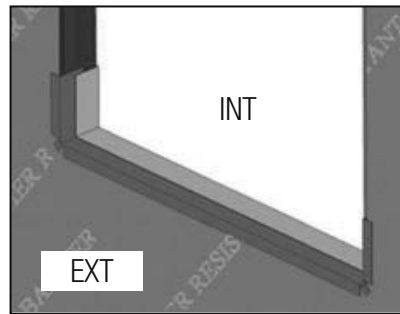
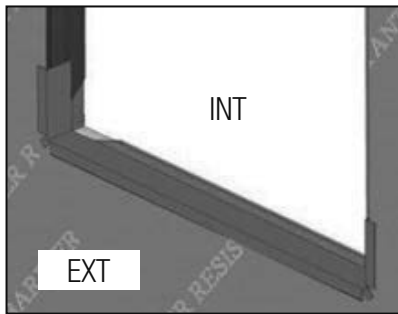

- F) Flashing tape must cover the entire sill plate. If needed, apply an additional flashing piece over the first one (*start from the exterior and work toward the interior*). Maintain a minimum 1" overlap. (Fig.10)

Step 5: Window Installation

- A) Remove all packaging material (blocks, pads, protectors, stretch wrap).
- IMPORTANT!** On vinyl double hung windows (Next Dimension Signature only), there are two red sash retainer clips attached to the bottom of the top sash. Do not remove these clips until after installation.
- B) Inspect and verify the following:
- The window is the correct size and specification.
 - The unit is free from any damage or defects.
- C) Contact your nearest Windsor distributor if there are any problems with Step B above.
- D) Apply sealant:
- Apply a 1/4" diameter bead of 100% neutral cure silicone sealant along the backside of the nailing flange.
 - Bead must run continuously around both sides and across the head, in line with and completely covering the nailing flange holes. (Fig. 11)
 - Use a discontinuous bead at the sill to allow for any drainage. Alternate using a 6" long bead with 1" gaps as shown below. (Fig. 12)
- E) Set the window into the rough opening. Center the unit in the opening, making sure there are equal gaps on both sides of the window.
- F) Temporarily tack the window into place using 2" galvanized roofing nails through the pre-punched holes on one top corner of the nailing flange. Do not drive the nails in fully.

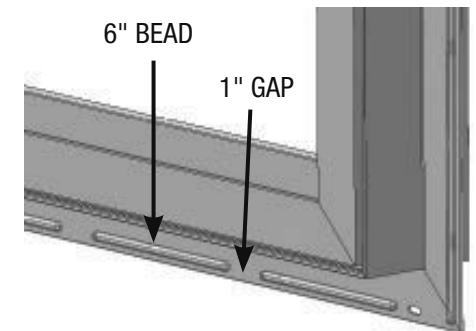
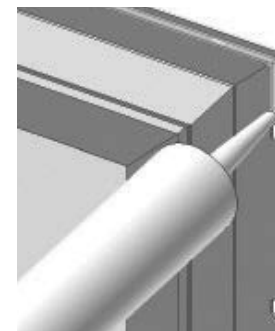

- G) Shim underneath the window until sill is level. Start with a shim at each corner no more than 1" from jamb corner. Add additional shims spaced evenly from the center of unit, make sure shims are spaced no more than 16" apart. Failure to evenly support sill can result in improper operation and performance and will forfeit the warranty.
- H) Check the unit for square using diagonal measurements. Shim window to ensure the unit is square. Multiple units must have shims under each mull. Casement units over 48" in height must have shims placed at the center to prevent bowing of jambs.
- I) **For double hung units: To ensure proper window operation and performance, it is very important to shim the middle of the unit to obtain equal frame widths as shown.**
- J) Nail all four corners in place through the pre-punched holes in the nailing flange.
- K) Make sure jambs, head and sills are straight. Additional shimming may be required. See below for minimum shim placement.
- L) Finish nailing the window into place through the pre-punched holes in the nailing flange, placing nails within 4" of each corner and no more than 8"-10" in between.

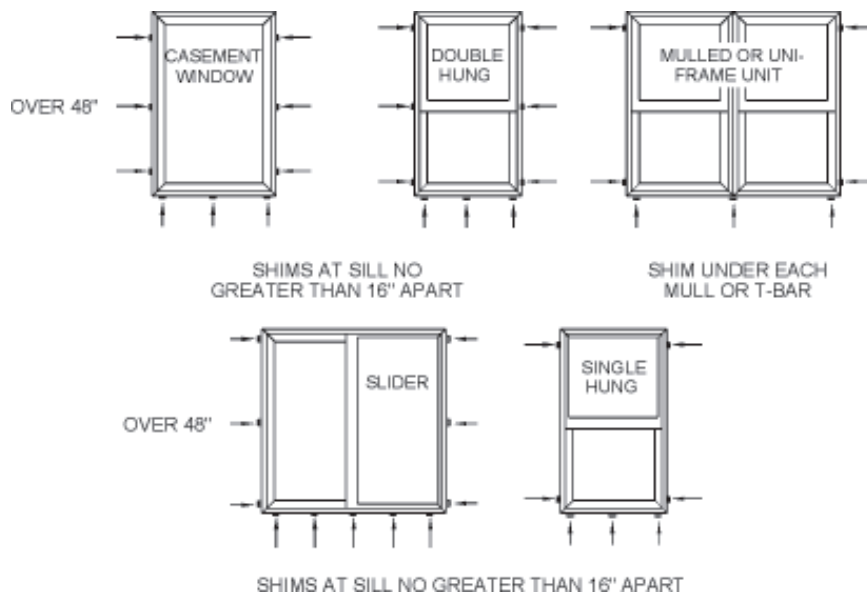

Step 6: Complete Flashing

- A) Cut and apply side flashing. Side flashing should run from the bottom of the sill flashing to 8" above the rough opening. (Fig. 13)
- B) If non-adhesive flashing is used, make sure all staple holes are sealed with silicone.
- C) Cut and apply head flashing. The head flashing should run slightly past the edge of the side flashing as shown. (Fig. 14)
- D) Flip down the top flap of the WRB.
- E) Tape the cut seams of the WRB. (Fig. 15)

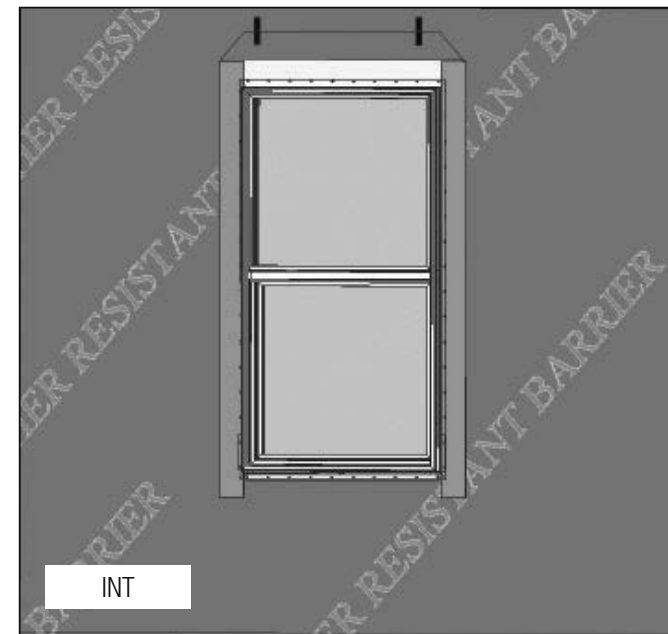

FIG. 13

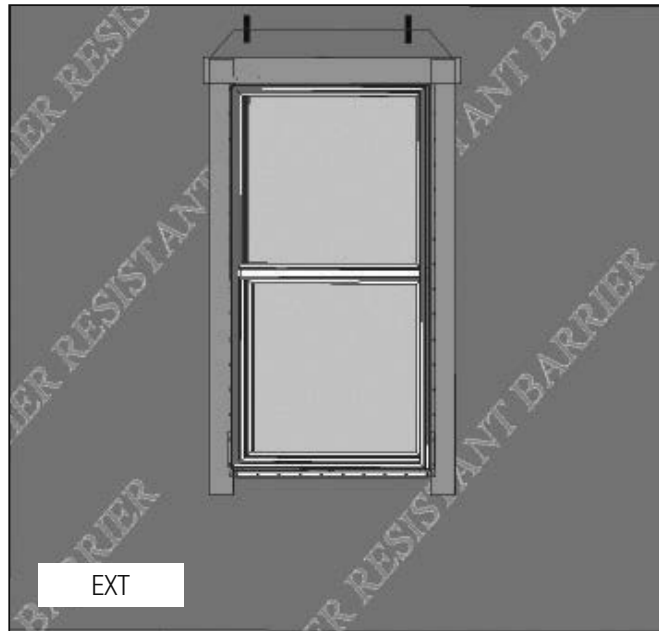

FIG. 14

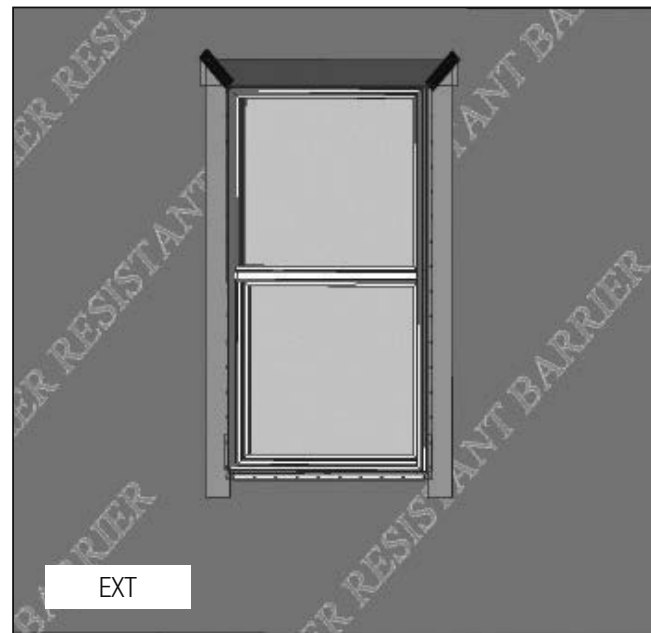
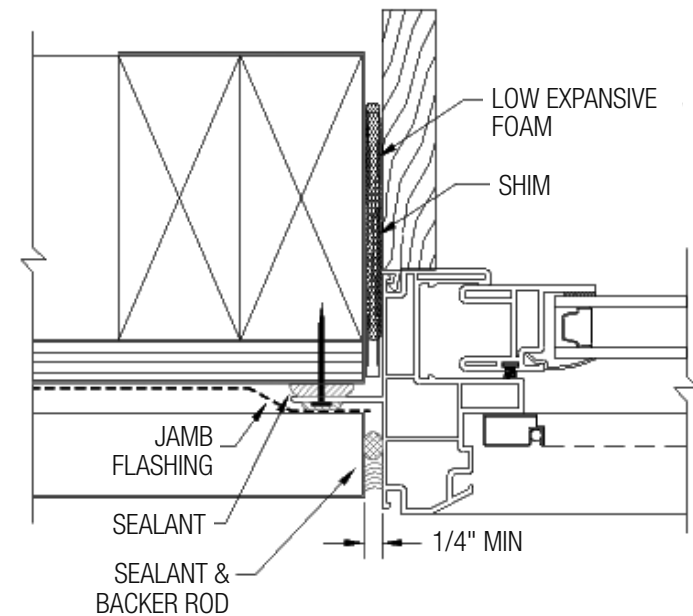

FIG. 15

Step 7: Seal the Exterior

- A) **WARNING:** Maintain a minimum of 1/4" between the window frame and any trim, siding or masonry. Failure to do so will forfeit all warranties (written or implied). Windsor Windows & Doors will not be held responsible for any claims or damages resulting from failure to follow these instructions.
- B) After siding or wall exterior is complete, apply backer rod and sealant between the window frame and siding material on both sides and sill. Make sure to use 100% neutral cure silicone sealant.

Note: For windows that have an integral J-channel/brickmould frame, this step is not needed when using siding that tucks behind the J-channel/brickmould frame. For windows that utilize a J-channel as an addition to the frame, the backer rod and sealant must be applied as shown below before application of J-channel.



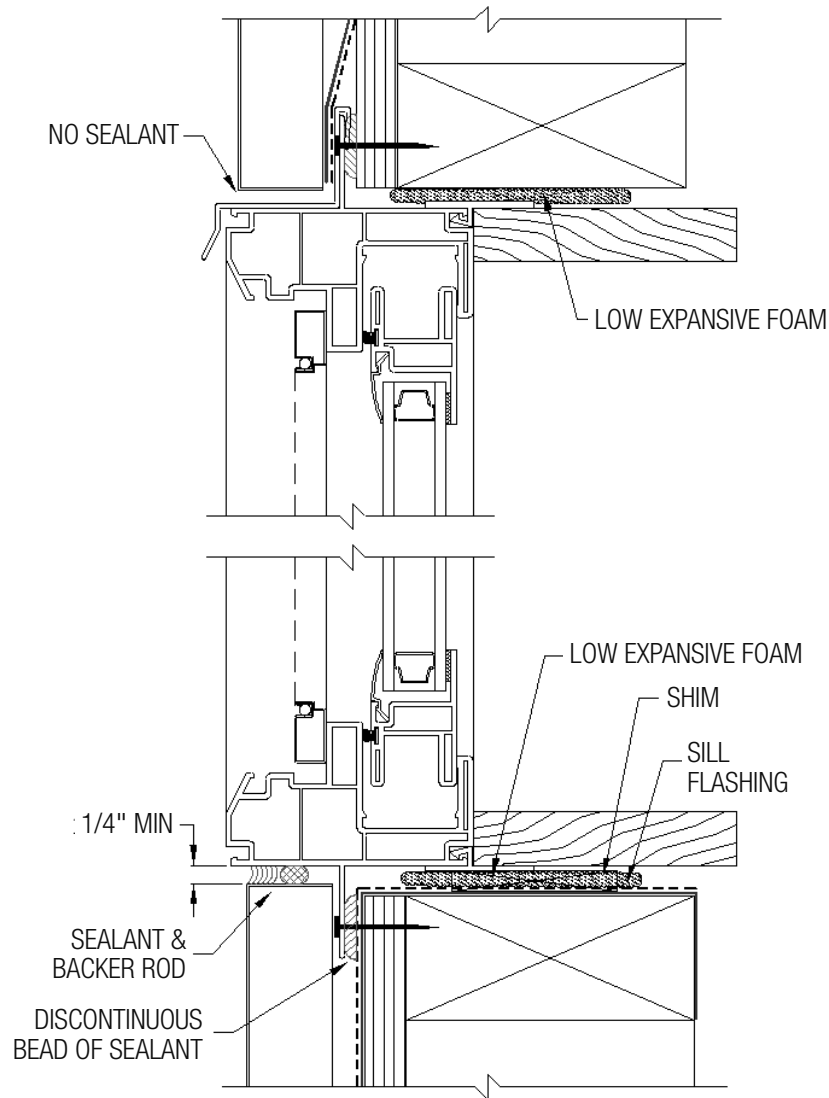

Step 8: Completing the Interior

- A) Insulate between the window frame and the rough opening using minimally expanding window and door spray foam insulation.
- B) Operate window unit to ensure proper operation. Sash will not operate correctly if window is out of square, over-shimmed or over-insulated.
- C) Remove all labels or shipping materials.
- D) Paint or stain all interior wood components.
 - **Painting:** Apply primer to un-primed wood surfaces that will be painted. Two coats of a good quality interior trim enamel latex or oil based should be applied in accordance to the paint manufacturer's specifications.
 - **Staining:** Apply stain according to manufacturer's recommendations. Two coats of a good quality, clear finish coat should be applied over any stain.
- E) **IMPORTANT:** Do not stain or paint any vinyl components.

If you have questions regarding the installation or adjustment of your Windsor products, please contact Windsor Windows & Doors directly at 1-800-218-6186. You may also complete and submit the form on the Contact page of our website (www.windsorwindows.com/contact-us) and one of our window specialists will promptly answer your question. On our website, you will also find Care and Use Guides to assist you in preserving your windows and patio doors.

Care and Use

An inspection of your windows should be made annually. Visit the Windsor website (www.windsorwindows.com) or contact your local independent Windsor distributor for information on the care and use of your product. Ask for the Care and Use Guide, which contains information on finishing, cleaning, what to look for during yearly inspections, general maintenance tips, sash/panel adjustment, sash/panel removal, screen removal and information on condensation.

NEXT DIMENSION – Limited lifetime Warranty

Windsor Windows & Doors, as manufacturer, warrants from the date of manufacture that all Next Dimension windows and patio doors will be free from defects in materials and workmanship that significantly impair their operation and proper usage for the lifetime of the home where originally installed, subject to the conditions and limitations within. This lifetime limited warranty applies to the entire window or door, including the glass. To achieve optimum performance from your Windsor products, and to preserve the warranty, please refer to the Windsor Care and Use Guide on our website, www.windsorwindows.com.

Windsor would like to thank you for selecting our Next Dimension vinyl products. We are confident that they will provide you with comfort, aesthetics and value for many years to come. As with any product warranty, there are certain limitations and disclaimers that must be included so all parties are assured the product is being installed and used properly. Our intent is to make this warranty as clear and user-friendly as possible.

Next Dimension products carry a **“Lifetime Limited Warranty,”** which provides coverage against workmanship and materials to the original owner-occupant, for as long as they occupy their single-family residence. If either the residence is sold, or these products are installed in a **“non single-family structure,”** then all warranties noted are limited to 10 years from the original date of manufacture, and by exclusionary items and conditions as noted.

There are five primary components to Next Dimension vinyl products, and the assurances and warranty provisions are specific to each:

1. **Next Dimension vinyl material** – Windsor warrants that, from the date of manufacture, vinyl material will not blister, corrode, flake, chip, peel or rot under normal conditions, so as to substantially impair the operation or performance of the Next Dimension products. If any of the vinyl material in our Next Dimension products should blister, corrode, flake, chip, peel or rot under normal conditions, or in the event the vinyl material fails, Windsor will provide a free Next Dimension vinyl replacement product or affected part, AND will pay charges Windsor determines to be reasonable associated with the installation, disposal and refinishing of the product replacement.
2. **Non-vinyl parts and components (including, but not limited to, such items as weatherstrip and hardware)** – Windsor warrants its Next Dimension products against premature component failure that substantially impairs the operation or performance of these products. In the event of such a failure, Windsor will provide no-charge replacement parts. *NOTE: There is no coverage for any additional costs, such as installation, disposal or refinishing.*
3. **Window Sash Opening Limiting Devices**
 - Always refer to applicable building codes when considering the purchase, installation and application for use as a Window Opening Control Device (WOCD). Also, refer to ASTM F2090-10 for additional information.
 - If Window Sash Opening Limiting Devices are going to be installed, carefully follow all information provided with the Window Sash Opening Limiting Devices, including installation, operation and safety information. *Proper installation of Window Sash Opening Limiting Devices, pursuant to applicable building codes, ASTM F2090-10, and the included installation information, along with application of tags/labels including the safety instructions left attached for the homeowner, allows these devices to be used as Window Opening Control Devices.*
 - Supervision is still required around windows where Window Sash Opening Limiting Devices have been installed.
4. **Insulated glass used in Next Dimension vinyl products** – Windsor warrants that under normal conditions, the insulated glass will not develop any material visual obstructions as a result of premature failure of the insulated glass seal. If a failure of seal occurs, Windsor will provide replacement insulated glass only, for the first 10 years free of charge. To the original owner-occupant in a single-family residence, Windsor extends the insulated glass warranty coverage for as long as they remain owner-occupant in a single-family residence, to provide replacement insulated glass at the cost of 50 percent of the current list price for that insulated glass, at the time the claim is submitted. In all cases, replacement glass will be shipped F.O.B. factory. *NOTE: There is no coverage for any additional costs, such as installation, disposal or refinishing.*
- 4a. **Blinds between the glass – This warranty applies in place of “insulated glass used in Next Dimension vinyl products.”** Windsor warrants that under normal conditions, the insulated glass will not develop any material visual obstructions as a result of premature failure of the insulated glass seal.

Blinds between the glass and insulated glass units in which they are installed are warranted for 10 years from the date of manufacture against failure of the operation of the shade/blind, failure of the insulated glass seal and failure of the external control mechanism for the blinds attached to the glass. Warranty coverage is excluded where Windsor determines failure is due to improper handling, improper cleaning, lint threads or some other obstruction within the insulated glass, and installation in a high heat environment, including, but not limited to, a storm panel or storm door applied, surrounding and/or enclosing the exterior of the blinds between the glass insulated unit. If a failure of seal occurs, Windsor will provide replacement insulated glass with blinds between the glass only free of charge. In all cases, replacement glass will be shipped F.O.B. factory. *NOTE: There is no coverage for any additional costs such as installation, disposal or refinishing.*

Laminated and/or impact glass – Windsor warrants against delamination of the inner liner (PVB) and extensive visual obstruction due to glass seal failure for a period of five years from the date of manufacture. If a failure of the seal or the inner liner occurs, Windsor will provide replacement insulated glass with laminated and/or impact glass only free of charge. In all cases, replacement glass will be shipped F.O.B. factory. *NOTE: There is no coverage for any additional costs such as installation, disposal or refinishing.*

4b. Laminated and/or impact glass – Windsor warrants against delamination of the inner liner (PVB) and extensive visual obstruction due to glass seal failure for a period of five years from the date of manufacture. If a failure of the seal or the inner liner occurs, Windsor will provide replacement insulated glass with laminated and/or impact glass only free of charge. In all cases, replacement glass will be shipped F.O.B. factory. *NOTE: There is no coverage for any additional costs such as installation, disposal or refinishing.*

5. Factory-applied painted vinyl – For a period of 10 years from the date of manufacture, Windsor will warrant that under normal conditions, the paint applied will be free from failure due to product defect and specifically against peeling, cracking, flaking or blistering from/on the painted surface and against significant ultraviolet discoloration (greater than 6 Delta E) caused by natural environmental atmospheric conditions. Windsor will not warrant any paint specific damage or alteration caused by the use of organic or chemical solvents or an environmental factor causing such damage including, but not limited to, stucco leach, acidic washes, hard tack tape and blowing sand.

As with all painted surfaces, natural weathering will occur over time. Exposure to different environmental elements will require regular cleaning and/or maintenance. In harsher conditions this could include up to semi-monthly cleaning and/or maintenance.

Please visit www.windsorwindows.com and follow Windsor's Care and Use Guide to clean, maintain and touch-up the paint.

CAUTION: MUST READ PRIOR TO PERFORMING PAINT TOUCH-UP OR PAINT REAPPLICATION! If touch-up painting is required, use only the specific paint acquired from Windsor for this purpose. FAILURE TO USE PAINT ORDERED FROM WINDSOR WILL RESULT IN FORFEITURE OF THE PAINT WARRANTY ON THESE WINDOWS! Painting professionals should review Windsor's Care and Use Guide at www.windsorwindows.com for touch-up and paint reapplication guidelines and contact Windsor directly to obtain this particular paint.

Storage and Handling

IMPORTANT! If vinyl windows and doors are not installed immediately upon delivery, they must be properly stored and protected until installed. If the vinyl product is not stored properly, distortion of the frames can occur affecting operation and performance. Vinyl windows and doors should be installed within 30-60 days of receiving.

Follow these procedures for proper storage of vinyl windows and doors:

- Remove stretch wrap immediately so the individual units can be exposed to circulated air.
- Do not store units outside or in direct sunlight. Allow sufficient spacing between products for ventilation.
- Never store vinyl units in a closed truck or other enclosure.
- Never stack or lean vinyl units against each other in the sun.
- Always carry vinyl units upright. Do not carry flat! Doing so can result in damage to the unit.
- Always store vinyl units vertically. Do not store windows flat or stack horizontally.
- Vinyl units must be stored in a clean, dry, well-ventilated and enclosed area.
- Vinyl windows with unsupported nailing fins should have their corners blocked and protected to prevent damage to the nailing fin.

Failure to follow these procedures will void our product warranty.

The remedies provided in this lifetime limited warranty will be forfeited by the occurrence of any of the following conditions:

- Improper installation of the window or door unit. (Installation instructions are factory applied on each unit.)
- Failure to properly finish/protect/maintain windows, doors and their components within 60 days of installation will forfeit any and all warranties for finishes, as well as warranties applicable to materials and components related to the finish. Failure to properly finish/protect wood components, CPVC components and/or all interior surfaces within 60 days of installation according to finish manufacturers' recommendations and industry standard finishing methods. Failure to properly maintain any and all finishes, interior or exterior, including finishes applied to components made from CPVC, wood, vinyl or aluminum. (See Windsor's Care and Use Guide at www.windsorwindows.com.)
- Damage caused by acts of God or some other cause outside Windsor's control.
- Conditions that exceed the design parameters of the windows.
- Improper removal of any permanent warning or identification labels from the product or products.
- Installation in a non-vertical or sloped application.
- Damage from accident, misuse or abuse.
- Alteration, modification or use for a purpose other than that for which it was intended. (Including, but not limited to, application of non-Windsor vinyl paint, drilling or screwing into the vinyl, and application or attachment of security systems to our product.)
- Application of any tint, UV limiting or sun blocking film to either interior or exterior surfaces of the glass, or the use of film shades.
- Use in or around ships, boats, trailers, campers, swimming pools, hot tubs, spas, saunas or greenhouses.
- Installation exceeding 5,000 feet above sea level, unless high altitude breather tubes have been factory installed.
- Exposure to harmful chemicals.

- Mulling (connecting or attaching) Next Dimension product(s) to those of another manufacturer.
- Failure to follow Windsor's Care and Use recommendations. (See Windsor's Care and Use Guide at www.windsorwindows.com.)
- Failure to maintain any factory painted finish. (See Windsor's Care and Use Guide at www.windsorwindows.com for maintenance information.)
- Failure to use paint ordered from Windsor to touch-up or reapply to vinyl windows with factory-applied paint.
- Failure to comply with the claims procedure outlined herein.

Exclusions – The following items or conditions are specifically excluded from the remedies provided by this warranty:

1. Remedies requested for any labor for removal, repair or replacement of defective parts, products or glass, or any repainting or refinishing costs, except as noted above.
2. Remedies requested for any consequential, incidental or punitive damages.
3. Remedies requested for damage caused by or adjustment required from:
 - a. Improper handling, installation or maintenance and/or delivery by others.
 - b. Exposure to conditions beyond performance specifications and/or design limitations.
 - c. Water infiltration other than as a result of a manufacturing defect.
 - d. Condensation and damage caused by the failure to resolve condensation.
 - e. Damage to glass, PVC or any other surfaces caused by brick wash, sanding, improper cleaning/washing, chemicals or airborne pollutants.
 - f. Minor scratches, and/or minor glass imperfections that do not impede or severely obstruct normal viewing area, and do not impact the structural integrity of the insulated glass.
 - g. Reflective distortion of any kind, including, but not limited to, color, tint, hue or waves inherent to annealed, coated, laminated and tempered glass.

- h. Alignment/location of inner grids of less than or equal to 1/8" from specified location.
 - i. Stresses to product caused by building defects, movement of the building in which the windows are installed, and/or components of that building, including building settlement.
 - j. Catastrophic weather or acts of God, including fire, wind or wind-blown objects.
 - k. Normal weathering, wear and tear.
4. Any applicable taxes and freight. (Replacement parts will be shipped to the closest Windsor distributor at Windsor's expense, or the option to ship directly to the homeowner at the homeowner's expense.)
 5. Remedies requested for glass breakage, including stress cracks, unless Windsor determines that the breakage or cracking is the result of a manufacturing defect.
 6. Remedies requested for special glazing.
 7. Remedies requested for rattling of, or noise caused by, inner grids or blinds between the glass due to, but not limited to, the lack of uniform supported structure of product, in which the operation of the product, or of another product, causes vibration harmonics into the Windsor product and induces inner grids or blinds between the glass to vibrate against the interior of the insulated glass, creating a noise.
 8. Windsor does not warrant the percentage of inert gas present in high-performance products. Gas dissipates over time at different rates depending upon use and conditions.
 9. Remedies requested for brass hardware finishes.
 10. Remedies requested for corrosion, tarnishing or operation of standard hardware in high salt spray environments.
 11. Remedies requested for wood texture, color variations and other wood characteristics within Windsor's specifications.
 12. Remedies requested for natural warping of wood components unless the "warp" exceeds 1/4"; warping includes bowing, cupping and twisting.
 13. Remedies requested for any special or custom product or item that is manufactured according to specification provided by the customer.

14. Remedies requested for any product in a size that is greater than that shown in our catalog; these products are purchased "as is" without any warranty.
15. Remedies requested for any product purchased without factory installed glazing; these products are purchased "as is" without any warranty.
16. Remedies requested for any product installed in structures that do not allow for proper management/drainage of moisture, including but not limited to, exterior insulation and finishing systems (EIFS) or "synthetic stucco" without engineered drainage system.
17. Remedies requested for products manufactured by others.

Limits of Liability – Where lawful, this warranty is in lieu of all other warranties, expressed or implied, including any implied warranties of merchantability or fitness for a particular purpose.

- No distributor, dealer, employee, salesperson or representative of Windsor has any authority to change or modify this warranty in any way.
- Windsor is not liable for any consequential, incidental or punitive damages, costs of installation of replacements, or costs of refinishing window or door components or adjacent parts/millwork.
- Windsor shall make the final determination as to whether or not a defect exists.
- In addition to, or in lieu of remedies provided herein, Windsor, at its sole discretion, may repair or replace a defective part or product, or refund a portion of the original purchase price.
- Windsor reserves the right to perform warranty work or arrange for another party to perform warranty work.
- In no event shall the liability of Windsor Windows or any seller of Windsor products arising out of a product defect exceed the original purchase price of the product.
- In the event any provision is found to be unenforceable, the remaining provisions shall remain in full force and effect.
- Any component or product repaired or replaced pursuant to this warranty is warranted for the remainder of the original warranty period.

- Affixed to Windsor’s windows are stickers identifying various WDMA and NFRC ratings. These ratings are not performance warranties because window performance will be impacted by conditions and may change over time. These ratings may also apply to single units only, not mulled configurations.
- This is not a warranty of future performance. It is only a warranty to provide the remedies described herein.
- Windsor is not responsible for determining the suitability of its products for particular applications and locations. Nor is Windsor responsible for compliance with building standards including applicable building codes.
- Windsor makes no warranties whatsoever with respect to accessories or parts not supplied by the manufacturer.
- Windsor may elect to perform repairs in situations where Windsor does not believe any warranty violations exist. This does not constitute a waiver of any of the provisions of this warranty.

Warranty Claim Procedure

If you have any questions regarding this warranty or have a claim under the provisions of this warranty (your “Claim”), please contact your local authorized independent Windsor distributor or one of our manufacturing facilities listed on the back of this brochure. To process a Claim, you must furnish the glass code (numbers and/or letters printed within/upon the insulated glass unit). If you have questions about locating the glass code, please contact one of the Windsor facilities OR REFER TO THE SUPPORT PAGE ON OUR WEBSITE. You must notify your local independent Windsor distributor or Windsor of any defects within a reasonable time, but no later than 30 days after the defect is discovered or reasonably should have been discovered, and within the period covered by the warranty. Windsor may require any defective parts be returned to Windsor or our closest distributor. In order to process a Claim, Windsor reserves the right to inspect the product before it is removed or modified in any way. Windsor field visits may result in service charges if a non-warranty site survey is required and/or requested.

Response by Windsor

Windsor will have 30 days to respond to your Claim, with an explanation of what Windsor is willing to do relative to your Claim. Please keep in mind that this response may include an explanation of some action Windsor would like to take, such as conducting further investigation, or it may state that Windsor is not willing to take any action. We point this out to make it clear that Windsor is committing to respond to your Claim, not agreeing to remedy the problems described in every Claim it receives. If you are in any way dissatisfied with Windsor’s response to your Claim, you must follow the steps of Windsor’s Dispute Resolution Process as outlined below.

Dispute Resolution Process

You and Windsor agree that any dispute arising out of or related to the Windsor products shall be settled pursuant to the terms of the Dispute Resolution Process defined in this warranty. The term Dispute shall include any claims related to the terms of this warranty, including claims related to the enforceability of any of its terms, and including claims alleging breach of this or any other warranty. The term Dispute shall also include claims alleging breach of contract, breach of warranty, tortious conduct on the part of Windsor, including, but not limited to, negligence, violation of state or federal laws, ordinances or regulations, and product liability claims, claims of fraud, misrepresentation and violation of any consumer protection statute or laws.

Notice of Dispute

The first step in the Dispute Resolution Process is for you and Windsor to attempt to resolve your Dispute informally. The first step is for you to provide Windsor with a Notice of Dispute. This can be found by going to www.windsorwindows.com/support, which will take you to a form that you need to fill out.

Response by Windsor

Windsor will have 60 days to respond to your Notice of Dispute by providing a written explanation of what Windsor is willing to do relative to your Dispute.

Waivers of Jury Trial and No Class Actions

IF YOU AND WINDSOR ARE UNABLE TO RESOLVE YOUR DISPUTE TO YOUR SATISFACTION, YOU CAN THEN SEEK TO FORMALLY RESOLVE YOUR DISPUTE BY RESORTING TO THE COURT SYSTEM. HOWEVER, YOU AGREE THAT YOU CAN ONLY DO SO AS AN INDIVIDUAL AND IN YOUR INDIVIDUAL CAPACITY, AND NOT AS A CLASS MEMBER OR REPRESENTATIVE IN A CLASS OR OTHER REPRESENTATIVE ACTION OR PROCEEDING. YOU ALSO AGREE THAT YOU CANNOT HAVE YOUR DISPUTE RESOLVED BY A JURY TRIAL, AND HEREBY WAIVE ANY RIGHT YOU MAY HAVE TO A JURY TRIAL, AND INSTEAD YOU AGREE THAT YOUR CASE WILL BE TRIED BY A JUDGE.

Waiver Opt-Out Option

As stated above, YOU CAN OPT OUT OF THE ABOVE WAIVERS. To do so, please to go www.windsorwindows.com/support and locate the Waiver Opt-Out Form. In order to opt out of these provisions, you must fill out the Waiver Opt-Out Form within one year of the date your Windsor products were manufactured, as indicated by the glass code on the product.

Failure to Follow Procedures or Processes

The failure to follow any of the steps outlined in the Claims Procedures or Dispute Resolution Process sections of this document does not alter, waive or void any of the terms of this document. The only way to alter, waive or void any of these terms is by "Opt Out" as described herein.

Applicable Law and Severability

This Dispute Resolution Process, including, but not limited to, issues related to its enforceability and effect, will be governed by the laws of the State of Minnesota without regard to conflict of law principles. If any term of this Dispute Resolution Process is found to be invalid or unenforceable in any particular jurisdiction, that term will not apply to that issue in that jurisdiction. Instead, that term will be severed with the remaining terms continuing in full force and effect.

Effective on Next Dimension products manufactured after 1/1/2017.